

Operating Instructions

SANDBLAST 2 / 3

LABORATORY EQUIPMENT
IN STAINLESS STEEL



REITEL Feinwerktechnik GmbH
Senfdamm 20 | 49152 Bad Essen
Phone: +49(0)5472-9432-0 | Fax: +49(0)5472-9432-40
www.reitel.com | info@reitel.com

Dear Customer!

The devices of the SANDUBLAST series are available either as recycling sandblasting device SANDUBLAST or as combined units SANDUBLAST 2 or 3 (cover image shows SANDUBLAST 3). The SANDUBLAST is a manual sandblaster. SANDUBLAST 2 or 3 are combining a recycling sandblasting device for blasting model castings with a Microfine jet blaster with two or three chambers. All the advantages of microblasting and recycling sandblasting technology are combined in one unit, suitable for the following applications: cleaning, buffing and polishing as well as removing oxide layers and special surface finishing with sandblasting beads. The special blasting principle and the heated chambers offer a constant flow of the abrasive that result in a smooth surface being created. Of course, the maintenance-free quick stop valve is integrated in the blasting unit as well, to provide precise and economic use of abrasives. Heated chambers prevent abrasive agglomeration leading to blocked nozzles. Different kind of abrasive graining and adjustable amounts per tank enable various surface qualities. All commercial abrasives from 25 to 250 my are applicable.

Prior to installation of the device operating instructions and especially the safety instructions must be read and followed by all personnel who use this device.

After having unpacked the device, please check carefully whether transportation damages of any kind have occurred. If that is the case, the carrier or manufacturer must be notified within 3 days. The company will **not** be responsible for any damages found after that.

These operating instructions must be read and followed by all personnel who use this device. To ensure quick access we recommend to keep it at a safe place near the device. In case of loss it can be ordered at a nominal fee from the manufacturer.

CONTENTS

1	EQUIPMENT	4
1.1	BASIC EQUIPMENT	4
1.2	SPECIAL ACCESSORIES.....	4
1.3	DEVICE COMPENENTS	5
1.4	TECHNICAL DATA.....	8
1.5	CHAMBERS AND NOZZLES	9
2	SAFETY NOTES	10
2.1	GENERAL SAFETY NOTES	10
2.2	SPECIFIC SAFETY NOTES.....	11
3	INSTALLATION	12
3.1	RECYCLING SANDBLASTER INSTALLATION	12
3.2	RECYCLING SANDBLASTER AND MICROFINE JET BLASTER INSTALLATION	12
4	OPERATION	13
5	TROUBLESHOOTING	14
6	MAINTENANCE	15
7	WARRANTY.....	16
8	DISPOSAL REGULATIONS	19
9	SPARE PARTS LIST	20
10	EU DIRECTIVE	FEHLER! TEXTMARKE NICHT DEFINIERT.

1 Equipment

1.1 Basic Equipment

- SANDUBLAST 2 and 3 are combining a recycling sandblaster with a Microfine jet blaster with 2 or 3 chambers (to be specified in the purchase order)
- Set of carbide nozzles (dependent on the number of chambers, see chart on page 5)
- Pair of abrasion resistant gloves, medium size (size 9)
- Filling funnel for abrasive material
- Assembly tool for changing tubes
- Power cord / plug
- Foot switch

1.2 Special Accessories

- Order-No.: 12900000 DUSTY MINI
- Order-No.: 17902000 DUSTY COMFORT
- Order-No.: 24604100 Pair of abrasion resistant gloves (size 7, small)
- Order-No.: 24604000 Pair of abrasion resistant gloves (size 9, medium)
- Order-No.: 24604200 Pair of abrasion resistant gloves (size 10, large)
- Various carbide nozzles
(see chart on page 5 – please indicate flow size upon placement of order)

1.3 Device Components

- 1 Power switch
- 2 Glass pane with protection film
- 3 Rubber seal (under glass pane)
- 4 Suction adapter
- 5 Fuse (with spare fuse)
- 6 Socket for power supply
- 7 Socket for foot switch
- 8 Socket for extraction unit
- 9 Compressed air outlet
- 10 Carrying handle
- 11 Interior light (LED)
- 12 Screw for opening the glass pane
- 13 Leather gauntlets
- 14 Screw plug for tank
- 15 Seal of the tank
- 16 Plexiglass lid of the tank
- 17 Nozzle head (in the tank)
- 18 Tank
- 19 Drain plug to drain the tank
- 20 Pressure regulator
- 21 Valve for residual water evacuation
- 22 Water separator
- 23 Sand sieve
- 24 Blast nozzle
- 25 Nozzle holder
- 26 Nozzle
- 27 Nozzle pen
- 28 Selector switch for abrasive media
- 29 Abrasive hose (nozzles)
- 30 Recycling nozzle
- 31 Angled screws for continuous angle adjustment of the recycling nozzle
- 32 Abrasive hose (recycling nozzle)
- 33 Opening in the base tray
- 34 Hose coupling recycling sandblaster (bottom side)
- 35 Funnel
- 36 Foot switch

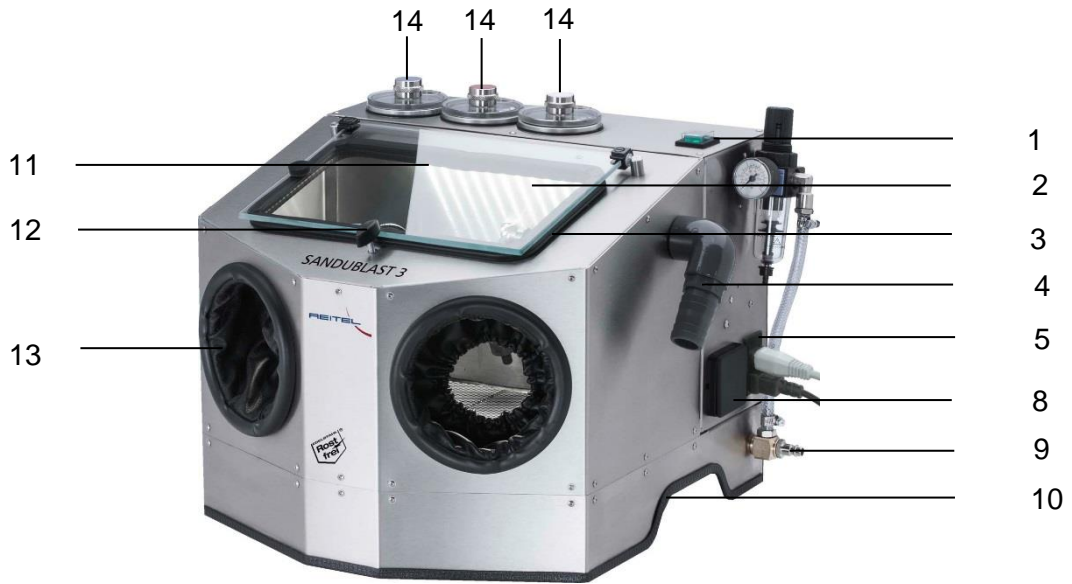

Fig.: Device view

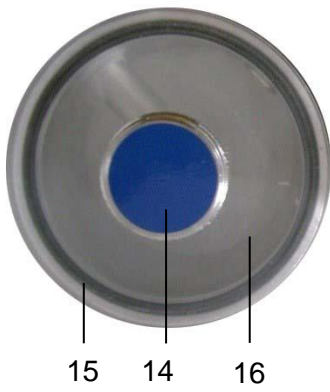

Fig.: closed tank

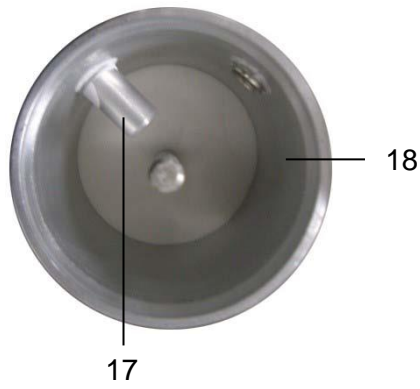

Fig.: open tank

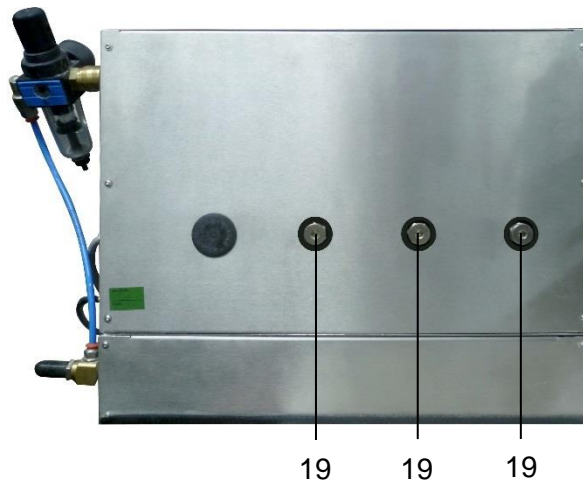

Fig.: Rear view

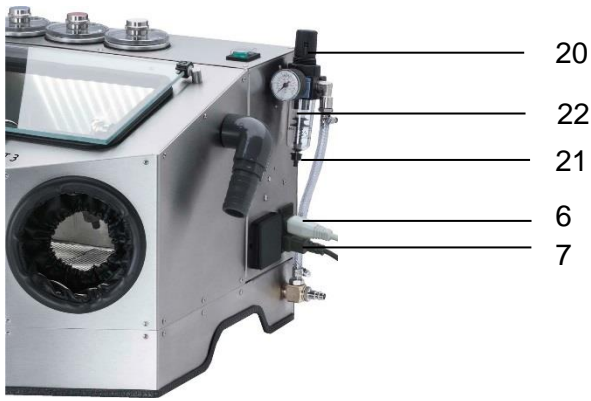

Fig.: Lateral view



Fig.: Funnel



Fig.: Foot switch

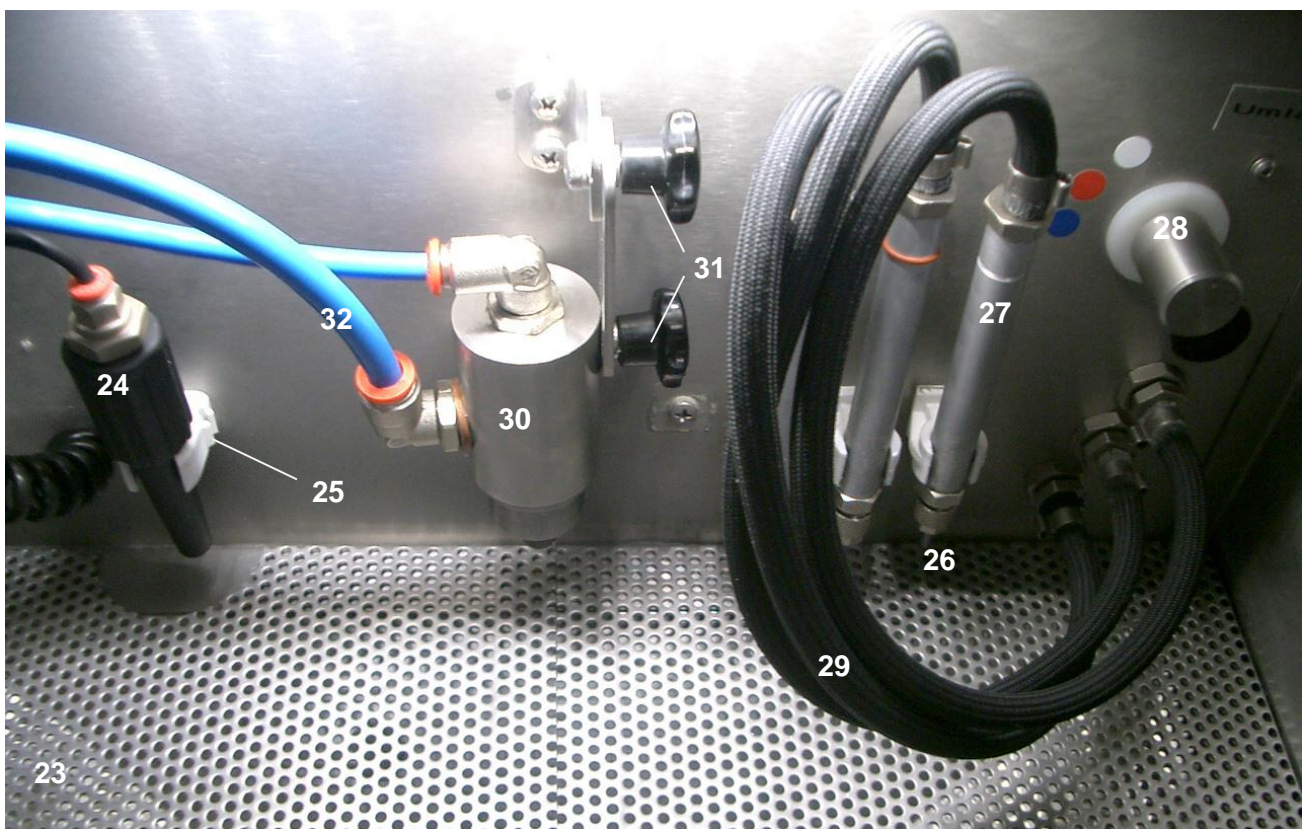

Fig.: Abrasive chamber

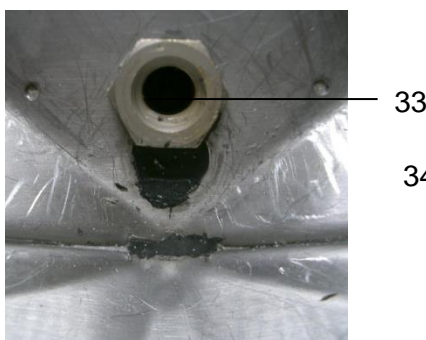

Fig.: Base tray

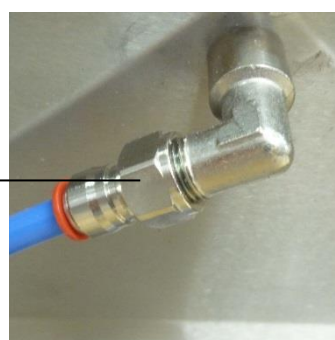

Fig.: Hose connection

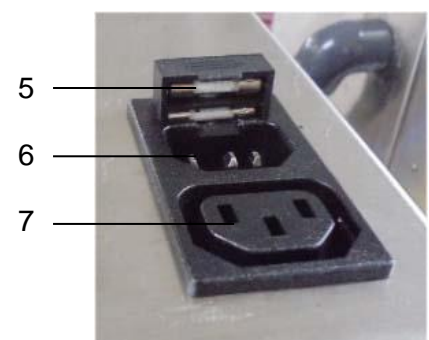

Fig.: Fuse

1.4 Technical Data

	SANDUBLAST 2	SANDUBLAST 3
Line voltage	230 V/50-60 Hz	
Current consumption	100 W	120 W
Height/width/depth	360+190/480/440 mm	
Weight	17 kg	18 kg
Air consumption	ca. 80 l/min.	
Pressure blaster	max. 6 bar	
Pressure chamber	0,5-6 bar	
Sound level	65 dB (A)	
Housing	Stainless steel	
Made in Germany (Subject to modifications)		
SANDUBLAST lid		
Glas pane	205 mm x 300 mm	
Opening	160 mm x 280 mm	
SANDUBLAST bottom		
Height x width	301 mm x 410 mm	
(incl. inclined front on the left and right side (176 mm))		

1.5 Chambers and nozzles

The Microfine jet blaster offers optimum surface quality for blasting different materials with abrasives, aluminium oxide, glass beads and combined abrasives from 25 to 250 μm .

	1. Chamber blue	2. Chamber red	3. Chamber white
Device with 2 chambers	25–125 μm	Not available	125–250 μm
Device with 3 chambers	25–75 μm	75–150 μm	150–250 μm

List of nozzles and chambers:

	1. Chamber blue	2. Chamber red	3. Chamber white
Device with 2 chambers	1,2 mm	Not available	1,5 mm
Device with 3 chambers	0,8 mm	1,2 mm	1,5 mm

Always use recommended nozzle size for chamber 1. Using other nozzle sizes than indicated in the chart for the other chambers doesn't provide optimum blasting results.



Fig.: Details on SANDUBLAST 2



Fig.: SANDUBLAST 3

2 Safety Notes

2.1 General Safety Notes

- All equipment undergoes final inspection and testing before leaving our factory. However, if equipment is damaged during shipping or through any other circumstances, it must not be used in service. Please check the device regularly for damages. Damaged parts should be replaced immediately.
- All power/air/water/gas sources should be rated for the demands of the device as listed in the technical data sheets. Maximum ratings must not be exceeded. All VDE (Verein Deutscher Elektro-Ingenieure) standards should be followed. Equipment should be grounded according to standards.
- Adherence to valid regulations regarding necessary checks (e.g. according to Accident Prevention & Insurance or electrical equipment) is exclusively taken over by the buyer/user of this product.
- This device has been designated to be used only for its intended purpose. All other applications must be prohibited for safety reasons as otherwise the manufacturer's warranty expires.
- The device should be set-up in a clean, well-ventilated room, if necessary under a hood.
- Supporting surfaces should be straight, flat and adequately stable.
- Don't place anything on top of the machine.
- To avoid injury, appropriate protection should be worn (e.g. gloves, safety glasses, safety shoes, hearing protection etc.)
- If the machine is defective or working improperly it must be taken out of service. In case of further use of the machine the owner will be held responsible for any consequential damage.
- To prevent accidents from water, fire or explosion, all power/air/water/gas sources should be turned off after working hours and during breaks, and secured against unauthorized access.
- When carrying out maintenance works or repairs or when opening the device always turn off the main power switch and unplug the whole unit.
- Repairs should be carried out only by the manufacturer or by qualified and certified personnel appointed according to chapter 7 – warranty.
- In case of leaking water out of housing or tank shut down device and call service.

2.2 Specific Safety Notes

Attention:

The abrasive grain sizes assigned to the chambers have to be adhered to. An abrasive grain size less than 25 μm is inadmissible, clogging the ventilation unit.

The chambers may only be opened when the device is not under pressure.

The lids of the tanks must always lie flat and clean and be screwed tight with the locking screw (14) before starting work with the device.

It is prohibited to use fluids and gaseous media. Application only according to manufacturer's instructions.

Regularly check the device for water collecting in the maintenance unit (see chapter 6).

- During operation the glass pane must be closed, connecting the device to an appropriate suction.
- To avoid injury wear abrasion resistant gloves and a mask.
- The device may only be operated with non-hazardous commercially available powdered abrasives.
- No harmful abrasives, gases or fluids shall be used.
- No other gases than compressed air shall be used with the device.
- The plug screw (14) may only be opened when the device is not under pressure.
- The blasting jet may only be aimed at objects to be cleaned, never at living beings.
- Do not install any dust-sensitive devices near the device.

3 Installation

The electrical equipment is ready for immediate use. The sealed plug can be connected directly to the mains supply 230 V/16 A. For installation please refer to safety notes in chapter 2.

3.1 Recycling sandblaster Installation

1. Now connect the device to the power supply by means of the plug or mains cable.
2. Establish compressed air connection (9) (3,5–6 bar). Set the pressure regulator (20) up to a max. of 6 bar. Don't exceed the max. pressure.
3. Connect the suction as follows:
 - Put the suction's plug in the socket outlet (8),
 - Secure suction tube to adapter (4),
 - Activate suction.
4. Insert the plug of the foot switch into the device socket (7).
5. The blasting nozzle (30) is continuously angle-adjustable.
6. Fill the tray's bottom of the recycling sandblaster with a sufficient quantity of abrasive media.

3.2 Recycling sandblaster and Microfine jet blaster Installation

Note:

Removing the tanks is only for repair purposes.

Use the funnel with filling adapter (30) for filling abrasive into chambers. To prevent overflowing don't exceed the maximum quantity of 450 ml abrasives. The filling area during filling must be clean (cover, screw thread, chamber inflation nozzle).

1. Fix the nozzles to the nozzle pens (27). (The nozzles are pre-assembled upon delivery. Please refer to notes in chapter 1.)
2. Fill required abrasive into the chambers (see chapter 2). Proceed as follows:
 - Release pressure, open screw plug (14) and remove plexiglass lid (16),
 - Completely introduce supplied funnel (35) (passing by at the nozzle head (17) and at the hose) and fill in abrasive
 - Filling height correct = up to the screw, ventilation slot remains free,
 - Remove residual abrasives from plug opening (if necessary use a brush),
 - Tightly close the plexiglass lid (16) and close with screw plug (14).

4 Operation

1. Turn the unit on with the main switch (1). If your extraction system is not linked to the unit, switch it on before operation.
2. The pressure of the chambers can be infinitely adjusted up to max. set 6 bar (uniform for all chambers). The recycling nozzle is operated with the pressure of the compressor. Pay attention to pressure setting of max. 6 bar. (Do not set the compressor pressure higher than 6 bar, since there is a risk of bursting hoses.)
3. Objects can now be placed in the device through the glass pane (2) and processed via the leather gauntlets (13). Be sure to wear protective gloves, eye and mouth protection!
4. The tanks (18) (color code chapter 1) can be selected via the selector switch (28) located inside the main chamber. With the selector switch (28) you can also select between recycling and microfine nozzles.
5. Start or stop the blasting process via the foot switch (36).
6. With the blast nozzle (24) objects can be blown off.
7. After finishing work, switch off the device with the main switch (1).

5 Troubleshooting

Jet becomes irregular	<ul style="list-style-type: none"> a. Abrasive might be dirty → Change abrasive, maybe take nozzle off and blow it through. b. Wrong nozzle being inserted → Please adhere to the nozzle configuration in chapter 1.3 (Important for chamber 1 of Microfine jet blaster). c. Not enough material in the chamber → re-fill abrasive. d. Worn nozzle → Replace nozzle.
Clumped abrasive, condensed water might be visible.	<ul style="list-style-type: none"> a. Humidity in the chamber → unscrew lid, turn device on and if necessary let it stand for several hours until it has evaporated - the chambers are heated. b. Only use dry abrasive material.
Very dusty working area.	<ul style="list-style-type: none"> a. Insufficient suction power: → change settings to increase suction power. b. Filter bag of the suction is full → if necessary replace filter bag. c. If necessary clean suction → e.g. change motor filter.
LED lamp (21) doesn't shine.	<ul style="list-style-type: none"> a. Unplug power cord, check it and replug power cord. b. Lamp defective → check it and if necessary replace it.
Trouble with foot switch (15).	Test the power cable and connect it properly.

6 Maintenance

- Please check the device regularly for damages. Pay attention to visible damages to the housing, cable or pressure hoses.
- Worn sand blast hoses (32) need replacing. They are not covered by warranty but considered normal wear and tear. Replacing hoses in the interior can be done on your own using common tools. Worn hoses in the device have to be replaced by your distributor or REITEL.
- The chambers should be emptied and cleaned on a regular basis. Release pressure from the chambers. After removing the drain screws (18) at the back of the device, the abrasive residues can be collected out of the open chamber using a vacuum cleaner.
- Remove abrasive material in the interior of the unit on a regular basis by loosening the tubing connection (36) of the recycling sandblaster. Then let the abrasive run out through the opening in the tray's bottom (35). Dispose of waste abrasive according to manufacturer's indications.
- Clean or replace the suction's filter regularly.
- Check the water separator, maintenance unit and pressure control (9) on a regular basis and if necessary let the water flow out through the valve (8).
- Clean the housing regularly with a damp cloth and polish it with the REITEL stainless steel spray.

Note

Clean and protect your device at regular intervals with the REITEL stainless steel care spray (order -no.: 90405000) to remove lime, plaster and dust as well as other contaminants from the surface of the equipment and to prevent corrosion. The spray creates a lasting, water repellent protective film which helps keep the equipment clean.

7 Warranty

We, REITEL Feinwerktechnik GmbH, offer a 1 year's warranty beginning from the proven date of purchase. This warranty covers all defects traceable to materials, design or workmanship. The following warranty regulations are applicable:

Within the warranty period Reitel Feinwerktechnik GmbH or an authorised distributor agrees at its sole option, to perform repair or replace this product at no charge covering all defects traceable to materials, design or workmanship. Warranty only applies to appropriate use and regular maintenance of this product according to the operating instructions. Claims under warranty are restricted to complementary performance. Additional claims, especially claims for indemnifications, are not covered by this warranty.

1.

Warranty claims have to be addressed to the distributor the product was purchased from or directly to our service department.

Contact:

REITEL Feinwerktechnik GmbH

Senfdamm 20

49152 Bad Essen

Germany

Phone: +49(0)5472-9432-32 (Service Department)

Phone: +49(0)5472-9432-0 (Reception)

Fax-No: +49(0)5472-9432-40

2.

In case of warranty claim application the sales receipt or your purchase invoice showing the date of purchase of the product and the serial number must be furnished. Securely pack and ship the device, freight charges prepaid, at your own risk to us, along with a report describing the defect. We reserve the right to decline warranty if this information has been removed or modified after purchase of the product or if they are not included in case of warranty claims.

3.

Warranty repairs have to be performed by REITEL Feinwerktechnik GmbH or by authorised distributors. Repairs performed by non-authorised companies will void the claim for refund since damages to the product resulting hereof are not covered by warranty.

4.

If the unit sent in for repair or replacement is still under the original warranty then warranty is to the end of the original 1 year warranty.

5.

If the unit is destined to be operated in another country than originally intended and manufactured for, modifications to the product might be necessary to comply to special technical and /or safety standards of that specific country. Such modifications are no defects traceable to materials, design or workmanship. and are therefore expressly excluded from warranty claims.

Modification costs or damages arising from operation of the product under deviating conditions are not covered by warranty.

6.

Exclusions from warranty:

- Service and maintenance work as well as repair and replacement of consumables according to our consumables' list
- Transportation cost of the machine or installation and dismounting expenses incurred
- Damages due to use of the product other than for its intended purpose
- Damages due to faulty installation or insufficient maintenance of the product (e.g. decalcification)
- Damages due to natural disaster e.g. lightning, water, fire, act of nature beyond control, war, inadequate line voltage, insufficient ventilation, no decalcification, insufficient care and cleaning or non-adherence to operation and maintenance instructions according to the accompanying operation guide.
- Damage due to use of the product other than in accordance with the instructions provided by REITEL Feinwerktechnik GmbH;
- The warranty does not cover the cost of removal and replacement of parts and accessories, unless supplied as original equipment by REITEL Feinwerktechnik GmbH
- All kind of damages occurred not directly at the device as well as consequential damages (e.g. damages to furniture due to a lack of water, downtime of the machine, material, lost working hours, wages and other consequential damages).

This warranty shall be rendered null and void if:

- the product has been subject to any modification, repair or replacement other than as authorised by REITEL Feinwerktechnik GmbH
- the product is continued to be operated despite a functional defect

7.

The warranty is device specific and may be claimed, within the warranty period, by any person who has legally acquired the device.

8.

Consumables are excluded from warranty. Spare parts are subject to a warranty coverage of 6 months against all effects traceable to materials, design or workmanship according to these warranty regulations.

9.

Legal default claims on the part of the purchaser remain unaffected by this warranty.

10.

We reserve the right to charge a fee if repair of the device is rejected and the device is destined to be sent back unrepaired.

11.

Please note:

Upon repair or replacement of this unit, personal data and settings might get lost or damaged. We don't accept liability for all kind of data loss. The customer is advised to backup essential programs and data before sending for service.

12.

This warranty shall be interpreted in accordance with German law to the exclusion of UN sales law. Place of jurisdiction is our business location.

13.

If any provisions of this warranty are judged to be illegal or unenforceable, the continuation in full force and effect of the remaining provisions will not be prejudiced. The provisions of this warranty judged to be illegal or unenforceable shall be construed so as to give effect to the intent manifested by the provision by the provision held invalid, illegal or unenforceable and to give effect to section 13 hereof.

14.

Should you need to borrow a device while your device is being repaired, please contact Messrs. REITEL or your distributor. These loans are a service for which availability cannot necessarily be guaranteed. After the warranty period, a fee may be charged for loan equipment as well as for shipping and packaging.

8 Disposal Regulations



According to valid laws our devices are properly disposed of according to B2B-regulations for proper disposal. Pls. contact your local dealer for additional information.

9 Spare Parts List

Best.-Nr. Reference	SANDBLAST 2-3 (46.5) Ersatzteilliste / Spare parts list 03/2019	Stck. Qty.	VE Unit
E7930500	Behälterdeckel farblos Transparent blast chamber cover	1	Stck piece
E7992600	Behälterknopf zum Verschließen Deckel Chamber lid locking knob	1	Stck piece
24598000	Düse 0,6mm für 50µ Nozzle 0,6mm for 50µ	1	Stck piece
24599000	Düse 0,8 mm für 110µ Nozzle 0,8 mm for 110µ	1	Stck piece
24600000	Düse 1,2 mm für 150µ Nozzle 1,2 mm for 150µ	1	Stck piece
24601000	Düse 1,5 mm ab 200µ Nozzle 1,5 mm from 200µ	1	Stck piece
E7015710	Filter (im Rückraum) Filter	1	Stck piece
E6189400	Fußtaster 1-pol. mit Kabel 1,65 m + Kaltgerätestecker Foot switch 1-pole	1	Stck piece
E6230200	Glasscheibe, inkl. Folie und Klebepunkte Glass panel, with protection foil	1	Stck piece
E6230600	Handdurchführung, 2 St. incl. Ledereinsatz für Lochd. 130mm Gauntlets, 2 pcs., made of genuine leather	1	Paar
24604200	Handschuhe für Sandstrahlarbeiten Größe 10 Pair of Gloves for sandblasting units, Size L	1	Paar
24604100	Handschuhe für Sandstrahlarbeiten Größe 7 Pair of Gloves for sandblasting units, Size S	1	Paar
24604000	Handschuhe für Sandstrahlarbeiten Größe 9 Pair of Gloves for sandblasting units, Size M	1	Paar
E6002300	Innenfilter Inner filter	1	Stck piece
E6230700	Kunststoff-Schutzfolie, 5 St. Plastic protection foil, 5 pcs.	1	Pack
E7336210	LED Lampe, mit Clips und Endkappe, ohne Trafo LED lamp, incl. Clips and end caps, without transformer	1	Stck piece
20280000	Lupe, mit Saugnapf, D75mm	1	Stck piece
20280000	Lupe, mit Saugnapf, D75mm	1	Stck piece
E7809120	Markierringe Handgriffel, Set rot, blau, schwarz	1	Set
E6202030	O-Ring 65 x 2,5 mm für Behälter (aussen) Sealing 65 x 2,5 mm for chamber (outside)	1	Stck piece
E7854500	O-Ring für Kammerdeckel 65x3,55 Sealing for chamber lid	1	Stck piece
E7336100	Rohr Acryl LED-Schutzrohr mit 1 Endkappe 240mm LED acrylic lamp protection, incl. 1 end cap 240mm	1	Stck piece
E7872900	Rohrclips 12 mm - Halter für Messingrohr im Behälter Tube clips 12 mm - Halter für Strahlgriffel	1	Paar two pcs
E6064800	Schalter mit Lampe grün 2pol. Power switch incl. green lamp (2 poles)	1	Stck piece

E6074310	Schlauch, H-PU-8/6 blau	1	m m
E6074310	Schlauch, H-PU-8/6 blau	1	m m
E7049500	Sicherung 10 Amp. Fuse 10 Amp.	1	Stck piece
E6283400	Strahldüse Umlaufstrahl, Trichterdüse mit Trennung an Madenschraube	1	Stck piece
E6283400	Strahldüse Umlaufstrahl, Trichterdüse mit Trennung an Madenschraube	1	Stck piece
E7931230	Strahlgriffel Alu komplett mit Verschraubung, ohne Düse und Markierring Abrasive pen, completed	1	Bgr assy
E7852340	Strahlschlauch für Strahlraum, mit 2 Steckröhrchen d=8 mm Hose inner sandblasting chamber, incl. 2 tubes	1	Stk./ Kammer pcs p. chamber
E7852350	Strahlschlauch Gehäuserückraum, 8x1 mm Hose back-housing, 8x1mm	1	Stk./ Kammer pcs p. chamber
E7299000	Umlaufstrahldüse komplett (Mischkammer mit Düsen) Mixing chamber with nozzles (assy)	1	Stck piece
E7299000	Umlaufstrahldüse komplett (Mischkammer mit Düsen) Mixing chamber with nozzles (assy)	1	Stck piece
E6207810	Ventil 2/2-nw4-24VAC (für Umlaufstrahl)	1	Stck piece
E6207810	Ventil 2/2-nw4-24VAC (für Umlaufstrahl)	1	Stck piece

10 EU DIRECTIVE

EU-Konformitätserklärung EC Conformity Declaration CE-Déclaration de Conformité

im Sinne der Niederspannungs-Richtlinie 2014/35/EU (Anhang III B)
according to Low Voltage Directive 2014/35/EU (Appendix III B)
au sens de la Directive Basse Tension 2014/35/EU (Annexes III B)

Name und Anschrift des Herstellers/Name and address of manufacturer/Nom et adresse du fabricant:

Reitel Feinwerktechnik GmbH
Senfdamm 20
49152 Bad Essen

Diese Erklärung bezieht sich nur auf das Gerät in dem Zustand, in dem es in Verkehr gebracht wurde; vom Endnutzer nachträglich angebrachte Teile und/oder nachträglich vorgenommene Eingriffe bleiben unberücksichtigt. Die Erklärung verliert ihre Gültigkeit, wenn das Produkt ohne Zustimmung umgebaut oder verändert wird./This declaration relates exclusively to the machinery in the state in which it was placed on the market and excludes components which are added and/or operations carried out subsequently by the final user. This declaration will become invalid if any unauthorized modification is made to the product./Cette déclaration concerne exclusivement les machines dans l'état dans lequel elles ont été mises sur le marché et exclut des composants ajoutés et/ou les opérations effectuées par la suite par l'utilisateur final. La présente déclaration perd sa validité si des modifications non-autorisées ont été apportées à la machine.

Hiermit erklären wir, dass nachstehend beschriebenes Gerät/**We hereby declare** that the machine described below/
Nous déclarons que la machine ci-dessous

Produktbezeichnung/Product name/Nom du produit: Umlauf- und Mikrofeinstrahler/
Combined sandblaster unit/
Sableuse Rotative et Micro-Sableuse

Typenbezeichnung/Type/Type: SANDUBLAST

allen einschlägigen Bestimmungen der Richtlinie 2014/35/EU sowie 2011/65/EU (RoHS 2) entspricht.
is in conformity with all applicable requirements of the Directive 2014/35/EC as well as 2011/65/EC (RoHS 2).
est conforme aux dispositions applicables de la Directive 2014/35/CE ainsi que 2011/65/CE (RoHS 2).

Angewandte harmonisierte Normen/Harmonised standards applied/Normes harmonisées appliquées:

DIN EN 61010-1:2020

11.02.2021

Ort, Datum
Place, Date
Lieu, Date

Daniel Reitel, Geschäftsführender Gesellschafter/Managing Director/
Directeur Général

Unterschrift/Signature/
Signature

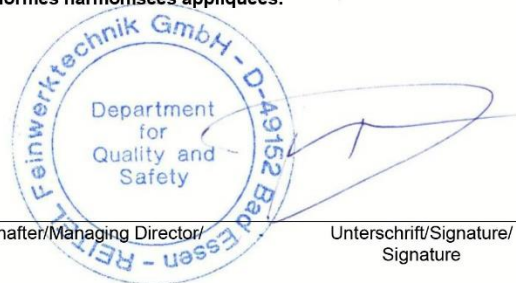

Manufacturing according to Quality Management ISO 9001:2015 incorporating established process standards.



REITEL Feinwerktechnik GmbH
Senfdamm 20 | 49152 Bad Essen
Phone: +49(0)5472-9432-0 | Fax: +49(0)5472-9432-40
www.reitel.com | info@reitel.com